

NORTH AMERICAN SEAL

& Packing Company

530 Van Ness Ave. Fresno, CA 93721
(559) 264-7325 – Fax: (559) 268-5207

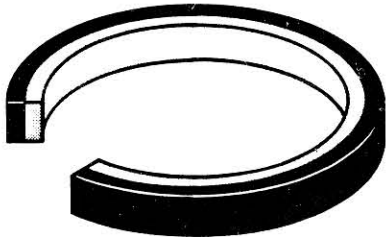

FLANGE SEALS

SERIES 11 (INCH SIZES)

CHARACTERISTICS

Series 11 Flange Seals are designed for use on all Hydraulic Flanged Tube, Pipe and Hose Connections, 4 Bolt Split Flange Type, as detailed in SAE Standard J518c. They provide a direct replacement for the O-rings without any modifications of the existing grooves.

Special sizes of Flange Seals may be economically produced for a variety of other applications, including manifold mounted pumps, stack valves and similar static hydraulic applications.

Flange Seals are a one piece, dual durometer static seal that consists of an outer lamina of Unithane 395A polyurethane. This material provides maximum extrusion resistance for the inner sealing lamina of Unithane 157A

polyurethane which exhibits extremely low compression set and has excellent sealing characteristics. Refer to Technical Bulletin US-82 for specific details on all Unithane materials.

Flange Seals are suitable for use in standard hydraulic fluids in a temperature range of -40 degrees F to $+220$ degrees F and 0 to 3000 P.S.I.

This unique combination of an outer extrusion resistant lamina bonded to an inner pressure responsive sealing lamina provides improved sealing performance and longer service life than normally can be obtained by O-rings or other more expensive sealing devices.

MATERIAL

- Outer lamina: Unithane 395A liquid cast Polyurethane, Duro 95A.
- Inner lamina: Unithane 157A liquid cast Polyurethane, Duro 57A.
- Fluid compatibility: See Material Specifications: Technical Bulletin US-82.

ORDERING INFORMATION

- For SAE J 518c 4 Bolt Split Flange Type Connections: refer to part number table on next page.
- For other sizes state either:
 - equivalent 'O'-ring size or,
 - OD, cross section (C/S) and height (H) of the seal required.
- We have tooling available for a large range of inch sizes and some millimeter sizes.

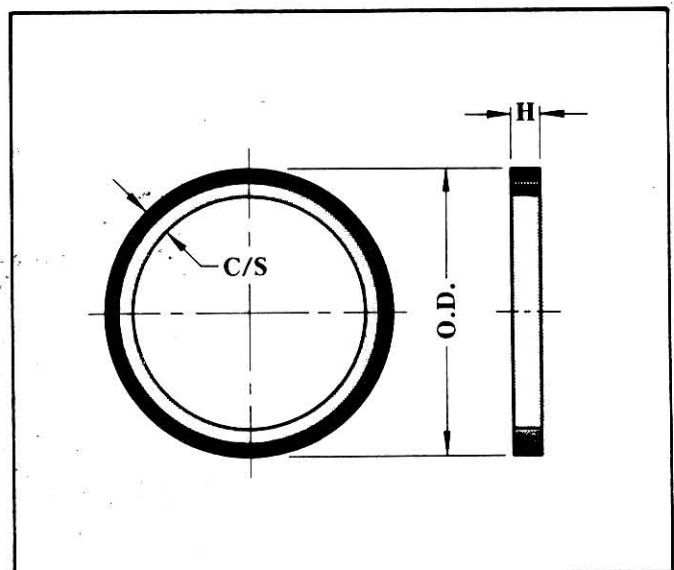

NORTH AMERICAN SEAL

& Packing Company

530 Van Ness Ave. Fresno, Ca. 93721

Telephone (209) 264-7325

FLANGE SEALS

SERIES 11
(INCH SIZES)

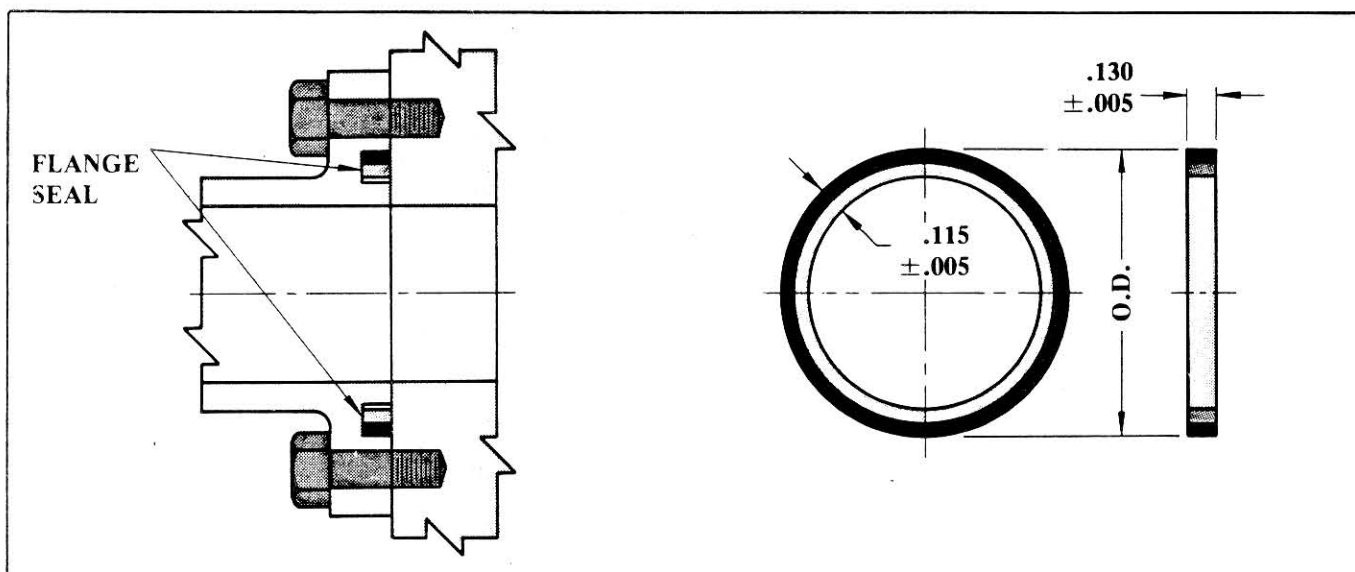

SIZES FOR SAE J518c 4 BOLT SPLIT FLANGE TYPE CONNECTIONS

PART NUMBER 11—	NOMINAL FLANGE SIZE, IN	FLANGE DASH SIZE	REPLACES O-RING SIZE NO.	OUTSIDE DIAMETER -.000 +.015
-08	1/2	-08	-210	1.005
-12	3/4	-12	-214	1.255
-16	1	-16	-219	1.565
-20	1-1/4	-20	-222	1.755
-24	1-1/2	-24	-225	2.125
-32	2	-32	-228	2.500
-40	2-1/2	-40	-232	3.005
-48	3	-48	-237	3.625
-56	3-1/2	-56	-241	4.115
-64	4	-64	-245	4.615
-80	5	-80	-253	5.615